

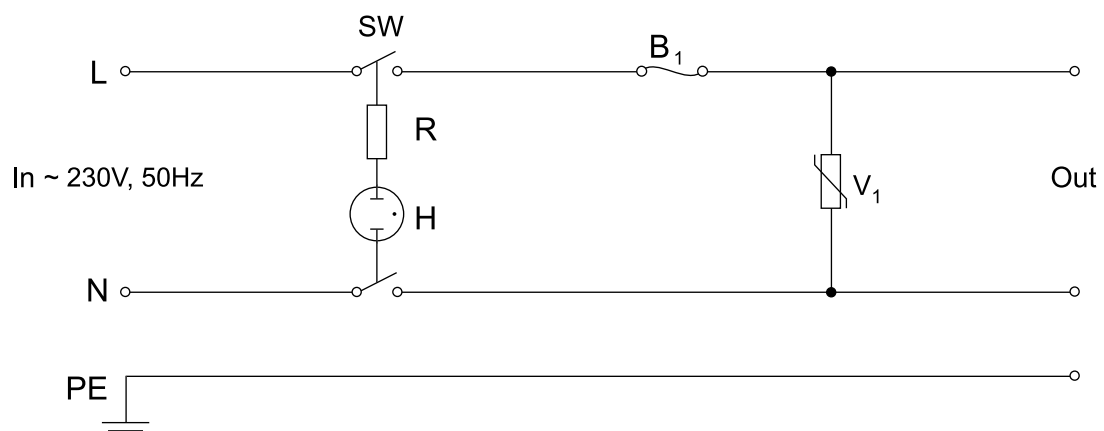



# PRODUCT CARD

## Electric diagram



### Elements:

B <sub>1</sub>	Fuse 10A, 250V
V <sub>1</sub>	Varistor 145J, 4,5kA (8/20μs)
H	Neon lights LTS 13N
R	Resistor 470kΩ
SW	Switch

DATE:

PREPARED:

CONFIRMED:

MODEL:

PAGE 2

PC-5FT G-B\*

KK-20/EN



# PRODUCT CARD

## Telephone protection diagram

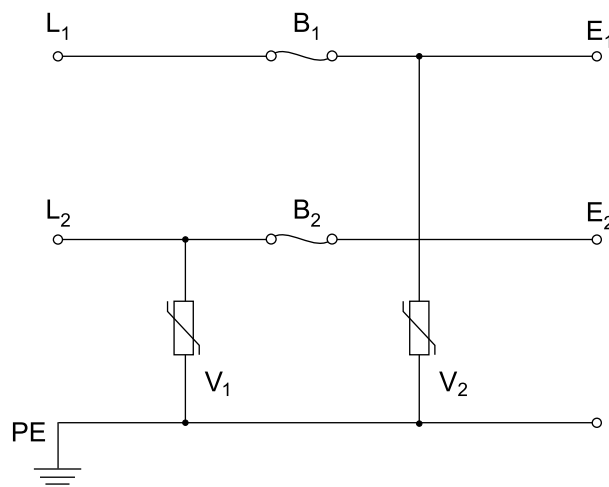

### Elements:

B <sub>1</sub> ;B <sub>2</sub>	Fuse 500mA, 250V
V <sub>1</sub> ;V <sub>2</sub>	Varistor 65J, 4,5kA

### Telephone protector data:

Static voltage	230V
Max. spike amperage	10kA (8/20 $\mu$ s)
Response time	25ns
Protection	2-line

DATE:	PREPARED:	CONFIRMED:	MODEL:	PAGE 3
			PC-5FT G-B*	KK-20/EN